



Central Purchase unit
National Institute of Technology Srinagar (J&K) -190006

Email: cpu@nitsri.ac.in

Document for Tender No.69 of 2019 Dated 05.04.2019

"Tender Notice for Invitation of bids for supply of Bolts for Installation of Shake Table" in CRFC
-0-0-0-

1. Sealed Bids are invited for supply of equipment having detailed Specifications as given in Annexure –I, from interested eligible bidders in a 2- bid format on the terms & conditions and as per the instructions given below from para-2,
2. **2. Techno-Commercial Bid, Containing the following documents in Envelope- A:-**
 - (a) Proof of being Original equipment manufacturer or Distributor/Marketing agent/ Authorized dealer in the shape of copy of agreement and registration under law in force.
 - (b) *The OEM (Original Equipment Manufacturer) of offered product should be ISO 9001:2015 and ISO 14001:2015 certified or certified by any other national or international regulatory body or a reputed manufacturer. The products quoted must also be certified.*
 - (c) PAN card & GST registration document of the firm and latest GST return copy
 - (d) ITR's of previous 3-years.
 - (e) *Proof of annual turnover of the firm for last three years in such trade, which shall not be less than Rs.20.00 lacs., with at-least one such contract worth not less than Rs. 05.00 lacs or two such contracts worth Rs. 10.00 Lacs to reputed Institutes/ organizations/ Departments.*
 - (f) Proof of availability of after-sale support & service.
 - (g) Supplier should have experience of installation of such equipment (Shake Table).
 - (h) Supplier shall have to furnish a test certificate from reputed/ accredited lab for bolts occurred to be supplied of desired specifications of Bolts.
 - (i) Bid security for Rs. 0.20 lacs in the form of CDR/BD/DD/TDR/FDR pledged to Officer In-charge, Central Purchase Unit NIT Srinagar (J&K) and tender document fee Rs.500/- in the form of DD, favoring of Director, NIT Srinagar. Tender without bid security /document fee shall be rejected.
 - (k) Bid form in the format given in Annexure-II duly filled.
 - (l) List of organizations/ Institutions where such equipment has been supplied.

3. Price Bid Containing the following in Envelope-B in the format as per annexure-III only.

- (a) Prices offered and quoted both in words & figures. Prices must be offered /quoted in the format enclosed as Annexure-III in INR only. The rates quoted should be covered with transparent tape.
- (b) The rate quoted should be FOR NIT Srinagar (J&K).
- (c) Bid price should be without over writing. However minor over writing should be clearly signed by the bidder. In case of any discrepancy between price quoted in figures and words, the price quoted in words will prevail. Bid price should be firm for the bid validity period.
- (d) All duties, taxes and levies (GST or other charges) payable, must be included but quoted separately.
- (e) As per SRO 129 of Government of Jammu & Kashmir, the institute is Exempted from State entry tax. The Institute will provide Entry tax exemption certificate to successful bidder with supply order.

4. Validity of Bids

Bids shall remain valid at least for 120 days from the date of opening of the bids.

5. Evaluation of Bids.

- (a) The purchaser shall first evaluate and compare the technical bids as per following criteria to determine the techno-commercially qualified bidders:
- (i) Properly filled and signed as per given formats
 - (ii) Conform to terms and conditions and technical specifications.
 - (iii) Are accompanied with Bid security and all other documents
- (b) *In the 2nd step, the financial bids of only those bidders who qualify from the above process will be evaluated to determine the final successful bidder.*

6. Award of contract.

- (a) Contract shall be awarded to the bidder whose bid is commercially-technically qualified and is offered at lowest reasonable evaluated price.
- (b) Successful bidder shall be notified about the award of the contract through a supply order where- in terms and conditions of supply shall be incorporated.

7. Payment & Performance Guarantee:

100% payment shall be made after successful receipt of goods in good condition as per specifications. 10% will however be retained as security deposit against performance guarantee for the warranty period.

8. Warranty and after sale service:

- (a) All items shall carry comprehensive standard warranty from the date of installation & commissioning.

9. Settlement of disputes.

Settlement of disputes if any shall be subject to the jurisdiction of Srinagar Courts only.

11. Liquidated Damages.

If the bidder after accepting the purchase order of goods/equipments or services, fails to deliver any or all of the goods/equipments with-in the specified period, a penalty of 0.50%(half percent) of the price value of the item per week or part thereof shall be imposed. However NIT Srinagar shall proceed on its own to consider the termination of the supply order, on the risk & responsibility of the defaulting bidder, in case it is found that supplier is not interested to supply and delay is causing academic loss.

12. Submission of Bids.

- (a) ***The last date for submission of bids is 15.04.2019 up-to 4.00PM.***
- (b) Bids should be properly sealed.
- (c) The two envelopes A & B should be separately sealed and superscripted as Techno-Commercial Bid & Price Bid. These two sealed envelopes should be sealed in a bigger Envelop. All (03) envelopes should be super-Scripted with the address of the Tender receiving Officer; Tender Number; due date of submission, Name of equipment/item/department and name of bidder in neat and bold letters..
- (d) Bids should be addressed to Officer In-charge, Central Purchase Unit NIT Srinagar (J&K190006)
- (e) Bids not from Srinagar shall be dispatched sufficiently well in advance so as to reach the destination as per scheduled time & date. NIT Srinagar shall not be responsible for any delay caused by Post or Courier agency.

13. Bid opening.

(a) The Technical Bid (Envelope- A) will be opened first on 16.04.2019 at 2.30 pm in the office room of the undersigned in the administrative block of the Institute.

Price Bid (Envelope-B) of the qualified bidders as detailed above will be opened subsequently. Interested bidders can attend the Bid opening.

14. Notwithstanding above, the purchaser reserves the right to reject any or all the bids received in response to this N.I.T. or withdraw it without assigning any reasons thereof.

15. For any future information or corrigendum or addendum regarding this tender, please be in touch with our website: www.nitsri.ac.in.

16. Any clarification may sought on the following emails:

- Indenter: bhat_javed@nitsri.ac.in

Officer In-charge
Central Purchase unit, NIT Srinagar
Email: cpu@nitsri.ac.in

No. NIT/CPU/19/4813

Dated 05.04.2019

Annexure-I
“Name &/Specifications of equipments ”

S. No.	Description of the item	Specifications	Quantity	Remarks
1.	Bolts	<u>Grouting studs 1 set, which includes:</u> i. M20 Grouting stud 570 mm long of High Grade Alloy Steel with Minimum Tensile Strength 1250 N/mm ² , Minimum Yield Strength 1124 N/mm ² and Minimum Shear Strength 750N/mm ² with Minimum elongation of 9%; Coated with Red Oxide of thickness 15-20 Microns ii. Nuts-2 No's and iii. Washer-1 No.	100 Sets	Refer Drawing for Bolt/Stud details (All the dimensions are in mm)

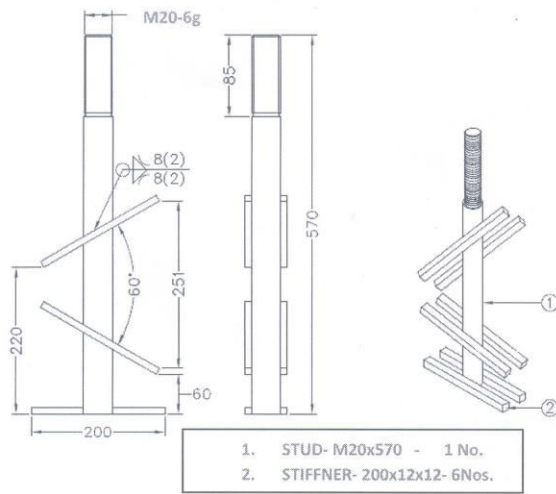

Bolt/Stud Details

Annexure-II
BID CHECK LIST

To,
Officer In-charge,
Central Purchase unit,
NIT Srinagar.

Ref: Tender No. _____ issued under No.: NITS/CPU/ 2019/.....
Dated..... for-----
ForDepartment

Sir,

With reference to above invitation for bids, we would like to say that we have gone through your bid document thoroughly and hence offer our competitive Technical/Price Bid in sealed envelope for the supply of various goods/equipment listed in your document.

The following documents constitute our Bid:

- | | |
|---|---------|
| • Technical specification/ literature attached:- | Yes/No |
| • Valid tax clearance certificate attached:- | Yes/ No |
| • OEM/ Authorized Dealership / certificate attached | Yes/ No |
| • Revenue stamp affixed. | Yes/ No |
| • Rates covered with transparent tape:- | Yes/ No |
| • Bid document fee deposited:- | Yes/ No |
| • Bid Security Receipt enclosed:- | Yes/ No |
| • Bid price in Indian Rupees and as per format given in annexure-III:- | Yes/ No |
| • Rater are FOR Srinagar including Installation/commissioning/
Training if required. | Yes/No |
| • Bid without correction/overwriting:- | Yes/ No |
| • Price Bid schedule in the requisite format | |
| • List of organization where this equipment has been supplied/Installed | |

Yours Sincerely

From M/S.....

Place:

Telephone No.....Email:

Date.....

Annexure-III

Price Schedule

S. No	Name of equipment/ Goods /item	Basic cost	GST	Any other tax	Total unit price	Quantity	Total Price
1							
2							
3							
4							
5							